

DATA SHEET

mifare[®]

MF RD700

**PEGODA Contactless Smart Card
Reader**

Preliminary Product Specification

November 2001

Revision 1.0

PUBLIC

MIFARE[®] Pegoda Contactless Card Reader**MF RD700****CONTENTS**

1	GENERAL INFORMATION	3
1.1	SCOPE.....	3
1.2	GENERAL DESCRIPTION.....	3
1.3	FEATURES.....	4
1.4	ORDERING INFORMATION.....	4
2	FUNCTIONAL UNITS	5
2.1	MF RD700 PEGODA BLOCK DIAGRAM.....	5
2.2	USB TYPE B PLUG.....	7
2.3	POWER SUPPLY	8
3	ELECTRICAL CHARACTERISTICS	9
3.1	OPERATING CONDITION RANGE.....	9
3.2	CURRENT CONSUMPTION.....	9
3.3	OPERATING DISTANCE.....	9
3.4	INTERFACE CHARACTERISTICS	9
3.4.1	<i>USB-Characteristics</i>	<i>9</i>
4	ELECTROMAGNETIC COMPATIBILITY.....	10
4.1	FCC CLASS A DECLARATION OF CONFORMITY	10
4.2	FCC DECLARATION OF CONFORMITY OF A CLASS A DIGITAL DEVICE.....	10
4.3	CE DECLARATION OF CONFORMITY	11
4.4	MECHANICAL SPECIFICATION.....	12
4.4.1	<i>Side View.....</i>	<i>12</i>
4.4.2	<i>Bottom View.....</i>	<i>13</i>
5	REVISION HISTORY	14

MIFARE[®] Pegoda Contactless Card Reader

MF RD700

1 GENERAL INFORMATION

1.1 Scope

This document describes the basic functionality and the electrical specifications of the MF RD700 'Pegoda' reader.

This contactless reader is designed for an easy reader adaptation to a PC to use this device for test and application purposes. Furthermore this reader can be taken as a reference design for new reader development based on the MF RC 500 reader IC.

1.2 General Description

The MIFARE[®] Pegoda reader, the MF RD700, is a new contactless reader based on the MF RC500 reader IC. The MF RC500 is member of a new family for highly integrated reader ICs for contactless communication at 13.56 MHz.

All layers of ISO14443A as well as the MIFARE[®] classic protocol are supported.

The Pegoda reader is designed to fulfil several requirements.

It covers all functionality of the MF RC500 to be able to use this reader as a reference design for a new hardware design based on the MF RC500 reader IC and is designed for easy PC adaptation and application development as well.

The Pegoda is the basic component for 2 evaluation kits:

- MF EV700 evaluation kit.
This kit is ready to use the Pegoda reader to develop a PC based application.
This package includes the Pegoda reader, a complete documentation including software libraries and description as well as the demonstration program MIFAREWnd covering all MIFARE and ISO 14443A commands.
- MF EV800 full evaluation kit
The MF EV800 gives the user the possibility to design his own reader either based on the Pegoda or taking the Pegoda as a reference design for an own development.
The MFEV800 package includes the MF EV700 package and additionally 5 MF RC500 samples and a reader PCB having the possibility to connect the reader using an RS 232 interface.

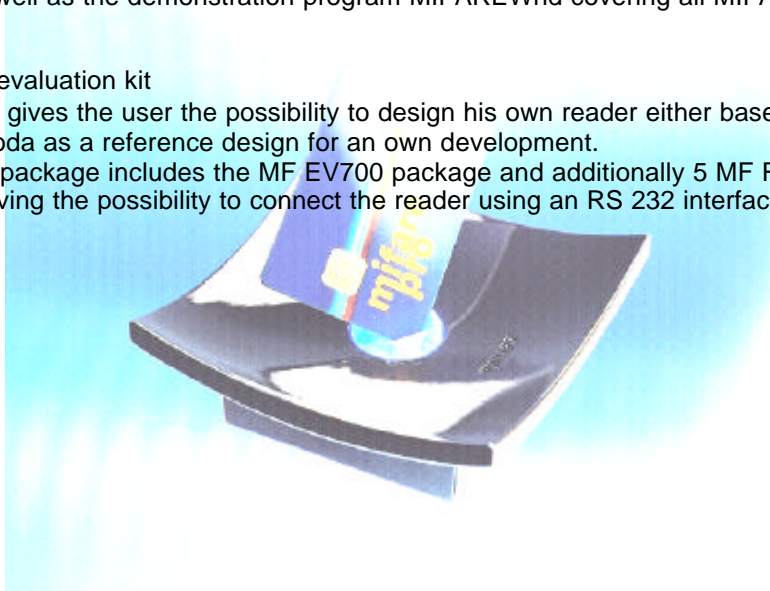

MIFARE[®] Pegoda Contactless Card Reader**MF RD700****1.3 Features**

- contactless smart card reader
- based on the MF RM 700 reader module containing the MF RC 500 reader IC
- contactless operating frequency 13.56 MHz
- Supports MIFARE[®] Dual Interface Card ICs and ISO 14443A part 1- 4
- Supports MIFARE[®] Classic protocol
- typical operating distance: 75mm
- CE and FCC compliant
- USB host interface
- USB bus powered 5 VDC power supply
- Unique serial number of each reader device
- supported by Windows 2000 and Windows 98

1.4 Ordering Information

The MF RD 700 'Pegoda' is available in 2 evaluation kits.

Type	12NC	Description
MF EV700	9352 699 27122	evaluation kit containing: MF RD700 Pegoda reader, documentation and software CD
MF EV800	9352 699 28122	full evaluation kit containing: MF RD700 Pegoda reader documentation and software CD MF RM700 reader module PCB with RS232 connector 5 MF RC 500 samples Card size antenna directly matched 50 Ohm matching circuit adapter

Table 1-1: MF RD700 Ordering Information

MIFARE[®] Pegoda Contactless Card Reader

MF RD700

2 FUNCTIONAL UNITS

2.1 MF RD700 Pegoda Block Diagram

The Pegoda reader, the MF RD700, is divided in two parts:

- MF RM700: reader module. This reader module is the basic print including the MF RC500, a μ -Controller and all interfaces to a host. Please refer to the data sheet 'MIFARE[®] MF RM700 Contactless reader module'.
- MF AN700: a flexible Pegoda antenna. Please refer to the application note 'MIFARE[®] MF RM 700 Antenna and matching adapter description'.

Figure 1 shows the Pegoda's basic functional components.

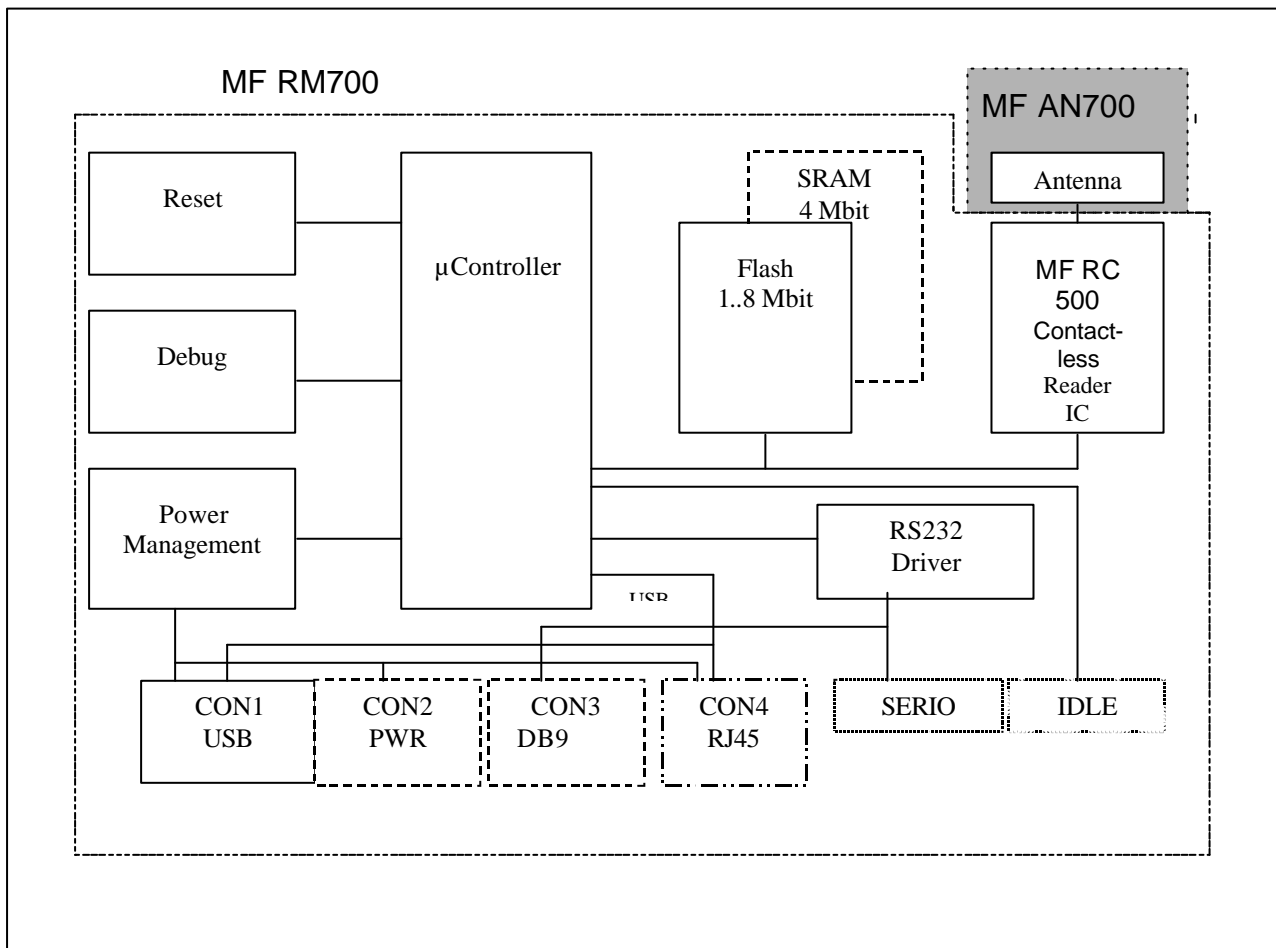

Figure 1. MF RD700 Block-Diagram

The Pegoda reader is designed to offer the user a great freedom to design an application. Several functional blocks can be identified.

MIFARE[®] Pegoda Contactless Card Reader**MF RD700**

Core component of the Pegoda is the MF RC500, the highly integrated ISO 14443A reader IC. For detailed information concerning the MF RC 500 refers to the data sheet: '*MIFARE MF RC500 Highly integrated ISO 14443 reader IC*'.

The RC 500 is used as an analog front-end unit to communicate via the antenna to a contactless chip card. All relevant data coding to send and receive data according to the ISO 14443A is done internally by the MF RC 500. The MF RC500 itself is controlled by a 16 bit μ -controller using an internal clock frequency of 36MHz generated by an external 8 MHz quartz oscillator.

The μ -controller handles the communication to the host PC via USB. The μ -Controller translates the serial protocol via USB into remote function calls and executes the appropriate command. To be able to implement the complete MIFARE Classic protocol and the ISO 14443-4 open protocol commands and to handle the host communication a 4 Mbit Flash Ram is implemented.

The design of the reader offers the possibility to update the firmware without hardware adaptation.

Note: This document is not intended to give detailed information concerning the MF RM700 and the MF AN700. Please refer to the related documents in the full evaluation package MF EV800.

MIFARE[®] Pegoda Contactless Card Reader

MF RD700

2.2 USB Type B Plug

The USB type B plug is the default configuration of the Pegoda reader to connect the reader to a host PC. This cable is part of the MF EV700 and MF EV800.

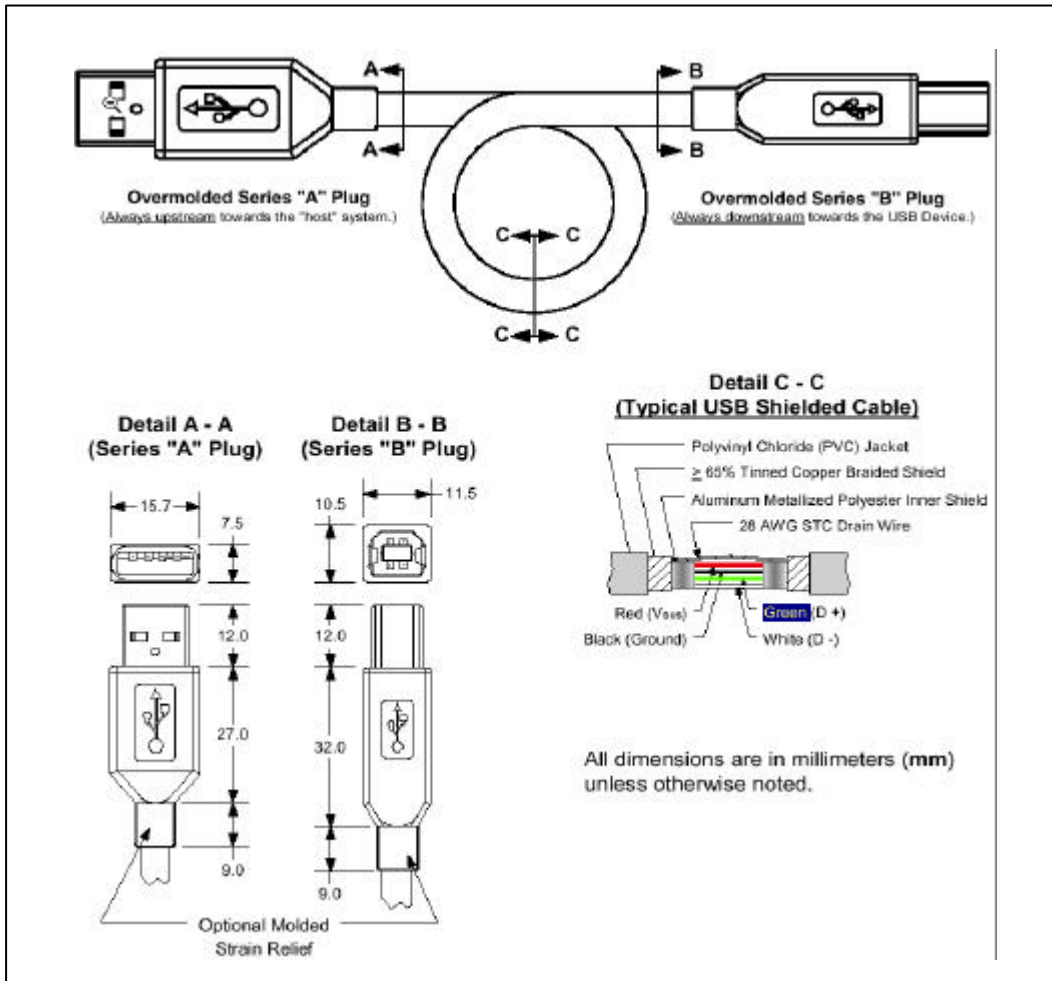

Figure 2. USB Type B connectors

The default configuration uses the USB cable to communicate to the Pegoda as well as to supply the 5 V supply voltage.

MIFARE[®] Pegoda Contactless Card Reader**MF RD700**

2.3 Power Supply

The MF RD700 is a bus powered 5 V USB device. No external power supply has to be connected to start to work with the Pegoda.

Notes:

In order to fulfil the USB specification version 1.1, the reader module behaves after power on like a low power device. Having sent an activate command, the Pegoda is activated and the reader module switches to an idle state resulting in an increased power consumption.

MIFARE[®] Pegoda Contactless Card Reader**MF RD700****3 ELECTRICAL CHARACTERISTICS****3.1 Operating Condition Range**

SYMBOL	PARAMETER	CONDITIONS	MIN	TYP	MAX	UNIT
T _{amb}	Ambient Temperature	-	-10	+25	+70	°C
VDD	DC Supply Voltage	DVSS = 0V	4.5	5.0	5.5	V

*Table 3-1: Operating Condition Range***3.2 Current Consumption**

SYMBOL	PARAMETER	CONDITIONS	MIN	TYP	MAX	UNIT
I _{DVDD}	Supply Current	StandBy	-	70	-	mA
I _{DVDD}	Supply Current	Idle, RF off	-	160	-	mA
I _{DVDD}	Supply Current	Idle, RF on	-	250	-	mA

*Table 3-2: Current Consumption***3.3 Operating distance**

SYMBOL	PARAMETER	CONDITIONS	MIN	TYP	MAX	UNIT
OD	operating distance	measured from the middle of the reader surface	-	0-75	-	mm

*Table 3-3. Operating Distance***3.4 Interface Characteristics****3.4.1 USB-CHARACTERISTICS**

SYMBOL	PARAMETER	CONDITIONS	MIN	TYP	MAX	UNIT
USB-baud	USB- baudrate	cable length max. 3 m	-	12	-	Mbaud

Table 3-4USB Characteristics

Note: The FCC and CE certification are only valid when the USB cable is equipped with the shielding components.

MIFARE[®] Pegoda Contactless Card Reader**MF RD700**

4 ELECTROMAGNETIC COMPATIBILITY

The MF RD700 fulfils the following requirements of electromagnetic compatibility:

FCC, Part 15 and CE.

4.1 FCC Class A Declaration of Conformity

This device has been tested and found to comply with the limits for a Class A digital device, pursuant to Part 15 of the FCC rules. These limits are designed to provide reasonable protection against harmful interference in a residential installation. This equipment generates, uses and can radiate radio frequency energy and, if not installed and used in accordance with the instructions, may cause harmful interference to radio or television reception. However, there is no guarantee that interference will not occur in a particular installation. If this equipment does cause interference to radio and television reception, which can be determined by turning the equipment off and on, the user is encouraged to try to correct the interference by one or more of the following measures:

- Reorient or relocate the receiving antenna
- Increase the separation between the equipment and the receiver
- Connect the equipment into an outlet on a circuit different from that to which the receiver is connected
- Consult the dealer or an experienced radio/TV technician for help.

Caution!

The Federal Communications Commission warns the users that changes or modifications to the unit not expressly approved by the party responsible for compliance could void the user's authority to operate the equipment.

Accessories: This equipment has been tested and found to comply with the limits of a Class A digital device. The accessories associated with this equipment are as follows:

- Shielded video cable

These accessories are required to be used in order to ensure compliance with FCC rules.

4.2 FCC Declaration of Conformity of a Class A Digital Device

We,

Philips Semiconductors Gratkorn GmbH

Mikronweg 1

8010 Gratkorn, Austria

declare that the product

MF RD 700,

FCC ID OWR40089

is in conformity with Part 15 of the FCC Rules.

MIFARE[®] Pegoda Contactless Card Reader**MF RD700**

Operation of this product is subject to the following conditions: (1) this device may not cause harmful interference, and (2) this device must accept any interference received, including interference that may cause undesired operation.

4.3 CE Declaration of Conformity

This Information Technology Equipment has been tested and found to comply with the following European directives:

Harmonised Standards applied	Description
EN 300 330: (2001-06)	Air interface of the radio systems pursuant to § 3(2) (Article 3(2))
EN 60950:1992	Health and safety requirements pursuant to § 3 (1) 1. (Article 3(1) a)
EN 301 489-9 :(2000-09)	Protection requirements concerning electromagnetic compatibility § 3(1)2,(Article 3(1)(b))

Manufacturer's Name: Philips Semiconductors Gratkorn GmbH

Manufacturer's Address: Mikronweg 1, A-8101 Gratkorn, Austria

Type of Equipment: Contactless Smart card reader

Model No.: MF RD700

Philips Semiconductors hereby declare that the equipment specified above conforms to the above Directive(s) and Standard(s), and said equipment is in conformity with the relevant harmonised standards as mentioned above.

MIFARE[®] Pegoda Contactless Card Reader

MF RD700

4.4 Mechanical Specification

4.4.1 SIDE VIEW

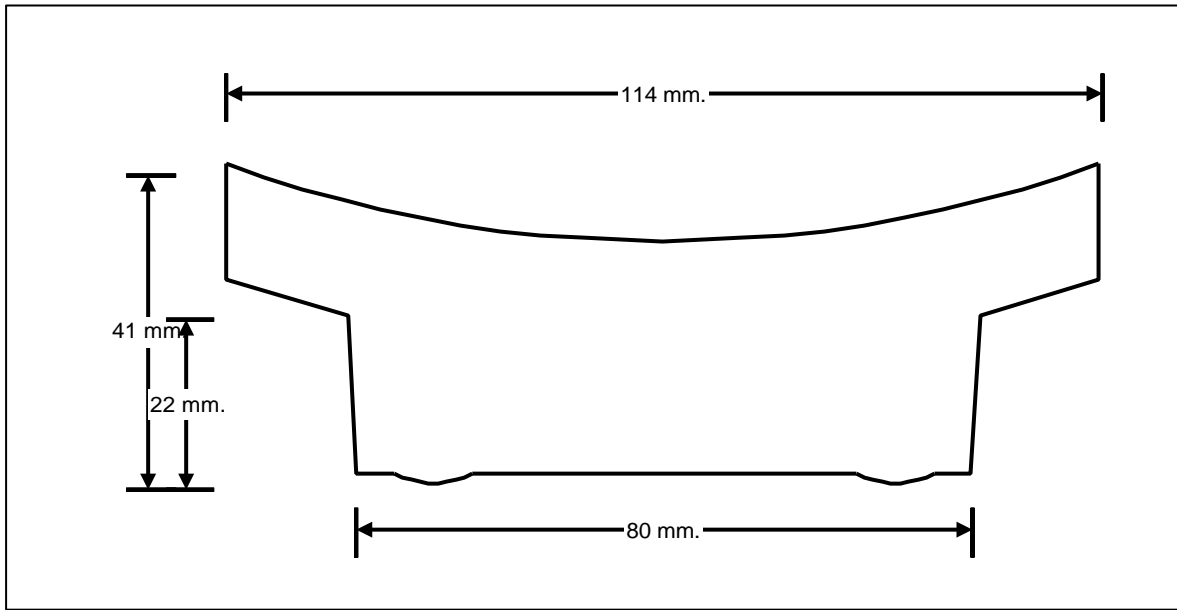

Figure 3. Side View

MIFARE[®] Pegoda Contactless Card Reader

MF RD700

4.4.2 BOTTOM VIEW

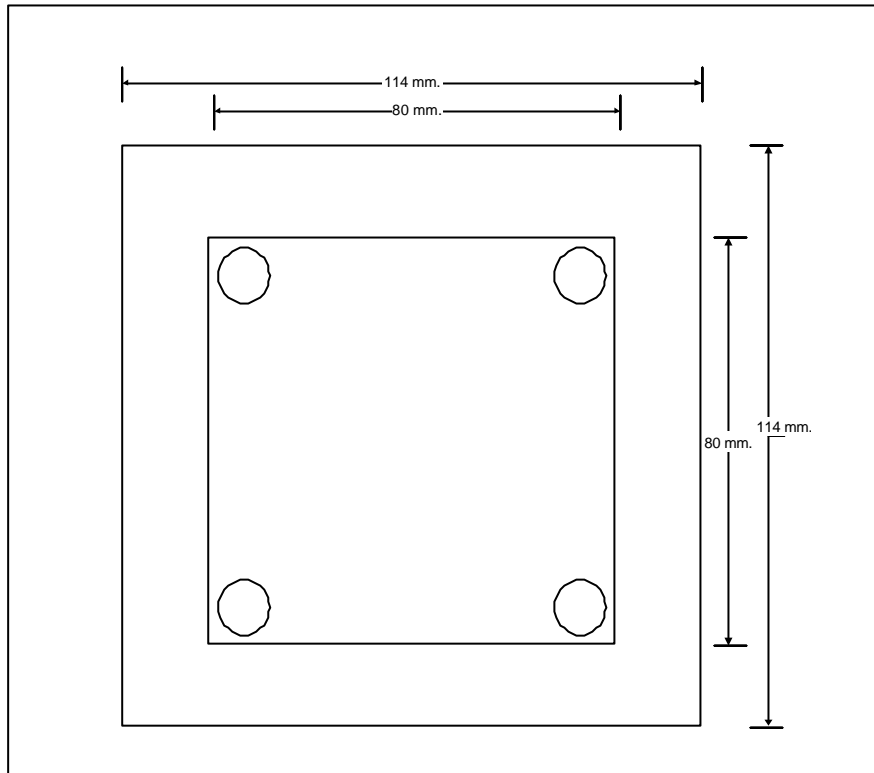

Figure 4. Bottom View

MIFARE[®] Pegoda Contactless Card Reader

MF RD700

5 REVISION HISTORY

REVISION	DATE	CPCN	PAGE	DESCRIPTION
1.0	November	-	16	first published version

Table 5-1: Document Revision History

Definitions

Data sheet status	
Objective specification	This data sheet contains target or goal specifications for product development.
Preliminary specification	This data sheet contains preliminary data; supplementary data may be published later.
Product specification	This data sheet contains final product specifications.
Limiting values	
Limiting values given are in accordance with the Absolute Maximum Rating System (IEC 134). Stress above one or more of the limiting values may cause permanent damage to the device. These are stress ratings only and operation of the device at these or at any other conditions above those given in the Characteristics section of the specification is not implied. Exposure to limiting values for extended periods may affect device reliability.	
Application information	
Where application information is given, it is advisory and does not form part of the specification.	

Life support applications

These products are not designed for use in life support appliances, devices, or systems where malfunction of these products can reasonably be expected to result in personal injury. Philips customers using or selling these products for use in such applications do so on their own risk and agree to fully indemnify Philips for any damages resulting from such improper use or sale.

Philips Semiconductors - a worldwide company

Argentina: see South America

Australia: 34 Waterloo Road, NORTHRYDE, NSW 2113,
Tel. +612 9805 4455, Fax. +612 9805 4466

Austria: Computerstraße 6, A-1101 WIEN, P.O.Box 213,
Tel. +431 60 101, Fax. +431 30 101 1210

Belarus: Hotel Minsk Business Centre, Bld. 3, r.1211, Volodarski Str. 6,
220050 MINSK, Tel. +375172 200 733, Fax. +375172 200 773

Belgium: see The Netherlands

Brazil: see South America

Bulgaria: Philips Bulgaria Ltd., Energoproject, 15th floor,
51 James Bourchier Blvd., 1407 SOFIA
Tel. +3592 689 211, Fax. +3592 689 102

Canada: Philips Semiconductors/Components,
Tel. +1800 234 7381

China/Hong Kong: 501 Hong Kong Industrial Technology Centre,
72 Tat Chee Avenue, Kowloon Tong, HONG KONG,
Tel. +85223 19 7888, Fax. +85223 19 7700

Colombia: see South America

Czech Republic: see Austria

Denmark: Prags Boulevard 80, PB 1919, DK-2300 COPENHAGEN S,
Tel. +4532 88 2636, Fax. +4531 57 1949

Finland: Sinikalliontie 3, FIN-02630 ESPOO,
Tel. +3589 61 5800, Fax. +3589 61 580/xxx

France: 4 Rue du Port-aux-Vins, BP 317, 92156 SURESNES Cedex,
Tel. +331 40 99 6161, Fax. +331 40 99 6427

Germany: Hammerbrookstraße 69, D-20097 HAMBURG,
Tel. +4940 23 53 60, Fax. +4940 23 536 300

Greece: No. 15, 25th March Street, GR 17778 TAVROS/ATHENS,
Tel. +301 4894 339/239, Fax. +301 4814 240

Hungary: see Austria

India: Philips INDIA Ltd., Shivsagar Estate, A Block, Dr. Annie Besant Rd.
Worli, MUMBAI 400018, Tel. +9122 4938 541, Fax. +9122 4938 722

Indonesia: see Singapore

Ireland: Newstead, Clonskeagh, DUBLIN 14,
Tel. +3531 7640 000, Fax. +3531 7640 200

Israel: RAPAC Electronics, 7 Kehilat Saloniki St., TEL AVIV 61180,
Tel. +9723 645 0444, Fax. +9723 649 1007

Italy: Philips Semiconductors, Piazza IV Novembre 3,
20124 MILANO, Tel. +392 6752 2531, Fax. +392 6752 2557

Japan: Philips Bldg. 13-37, Kohnan 2-chome, Minato-ku, TOKYO 108,
Tel. +813 3740 5130, Fax. +813 3740 5077

Korea: Philips House, 260-199, Itaewon-dong, Yonsan-ku, SEOUL,
Tel. +822 709 1412, Fax. +822 709 1415

Malaysia: No. 76 Jalan Universiti, 46200 PETALING JAYA, Selangor,
Tel. +60 3750 5214, Fax. +603 757 4880

Mexico: 5900 Gateway East, Suite 200, EL PASO, Texas 79905,
Tel. +9 5800 234 7381

Middle East: see Italy

Netherlands: Postbus 90050, 5600 PB EINDHOVEN, Bldg. VB,
Tel. +3140 27 82785, Fax +3140 27 88399

New Zealand: 2 Wagener Place, C.P.O. Box 1041, AUCKLAND,
Tel. +649 849 4160, Fax. +649 849 7811

Norway: Box 1, Manglerud 0612, OSLO,
Tel. +4722 74 8000, Fax. +4722 74 8341

Philippines: Philips Semiconductors Philippines Inc.,
106 Valero St. Salcedo Village, P.O.Box 2108 MCC, MAKATI,
Metro MANILA, Tel. +632 816 6380, Fax. +632 817 3474

Poland: Ul. Lukiska 10, PL 04-123 WARSZWA,
Tel. +4822 612 2831, Fax. +4822 612 2327

Portugal: see Spain

Romania: see Italy

Russia: Philips Russia, Ul. Usatcheva 35A, 119048 MOSCOW,
Tel. +7095 247 9145, Fax. +7095 247 9144

Singapore: Lorong 1, Toa Payoh, SINGAPORE 1231,
Tel. +65350 2538, Fax. +65251 6500

Slovakia: see Austria

Slovenia: see Italy

South Africa: S.A. Philips Pty Ltd., 195-215 Main Road Martindale,
2092 JOHANNESBURG, P.O.Box 7430 Johannesburg 2000,
Tel. +2711 470 5911, Fax. +2711 470 5494

South America: Rua do Rocio 220, 5th floor, Suite 51,
04552-903 Sao Paulo, SAO PAULO - SP, Brazil,
Tel. +5511 821 2333, Fax. +5511 829 1849

Spain: Balmes 22, 08007 BARCELONA,
Tel. +343 301 6312, Fax. +343 301 4107

Sweden: Kottbygatan 7, Akalla, S-16485 STOCKHOLM,
Tel. +468 632 2000, Fax. +468 632 2745

Switzerland: Allmendstraße 140, CH-8027 ZÜRICH,
Tel. +411 488 2686, Fax. +411 481 7730

Taiwan: Philips Taiwan Ltd., 2330F, 66,
Chung Hsiao West Road, Sec. 1, P.O.Box 22978,
TAIPEI 100, Tel. +8862 382 4443, Fax. +8862 382 4444

Thailand: Philips Electronics (Thailand) Ltd.,
209/2 Sanpavuth-Bangna Road Prakanong, BANGKOK 10260,
Tel. +662 745 4090, Fax. +662 398 0793

Turkey: Talapasa Cad. No. 5, 80640 GÜLTEPE/ISTANBUL,
Tel. +90212 279 2770, Fax. +90212 282 6707

Ukraine: Philips Ukraine, 4 Patrice Lumumba Str., Building B, Floor 7,
252042 KIEV, Tel. +38044 264 2776, Fax. +38044 268 0461

United Kingdom: Philips Semiconductors Ltd., 276 Bath Road, Hayes,
MIDDLESEX UM3 5BX, Tel. +44181 730 5000, Fax. +44181 754 8421

United States: 811 Argues Avenue, SUNNYVALE, CA94088-3409,
Tel. +1800 234 7381

Uruguay: see South America

Vietnam: see Singapore

Yugoslavia: Philips, Trg N. Pasica 5/v, 11000 BEOGRAD,
Tel. +38111 625 344, Fax. +38111 635 777

Published by:

Philips Semiconductors Gratkorn GmbH, Mikron-Weg 1, A-8101 Gratkorn, Austria Fax: +43 3124 299 - 270

For all other countries apply to: Philips Semiconductors, Marketing & Sales Communications, Internet: <http://www.semiconductors.philips.com>
Building BE-p, P.O.Box 218, 5600 MD EINDHOVEN, The Netherlands, Fax: +3140 27 24825

© Philips Electronics N.V. 1997

SCB52

All rights are reserved. Reproduction in whole or in part is prohibited without the prior written consent of the copyright owner.

The information presented in this document does not form part of any quotation or contract, is believed to be accurate and reliable and may be changed without any notice. No liability will be accepted by the publisher for any consequence of its use. Publication thereof does not convey nor imply any license under patent- or other industrial or intellectual property rights.

**Philips
Semiconductors**



PHILIPS